

Power Supply Meets AMD K8 Low-Power Mobile Specification

This application note describes a two-phase, synchronous, step-down converter that is fully compliant with the AMD K8 Low-Power Mobile Specification. It includes details of the circuit operation, schematic, bill of materials, and a 1.2 volt, 27.3 Amp reference design with test data.

This application note describes a two-phase, synchronous, step-down converter that uses the MAX1937 to achieve a power supply that is fully compliant with the AMD K8 Low-Power Mobile Specification.

The design uses the standard K8 VID table with a -100mV offset from the selected VID voltage. An active offset method implements the required -100mV offset. The specified "droop" or voltage positioning value for this application is 50mV.

Details of the active offset circuit are presented, along with the schematic and bill of materials for the complete power supply. A 1.2 volt, 27.3 Amp reference design along with test data is also presented.

For more details on the 2-phase synchronous step down converter (voltage positioning etc.), please refer to the [MAX1937-MAX1939 Data Sheet](#).

Active Offset

The active offset circuit is shown in Figure 1. It is essentially a precision 1-mA current source. The circuit consists of resistors R51, R52, R53, R54, R55 and the LMX321 op amp U2. The circuit accepts a 2V input from the reference voltage (pin 12) of the MAX1937 and maintains 2V, with the polarity shown, across the 2k Ω resistor R55. The resulting 1mA current in the resistor flows in the 100 Ohm feedback resistor R8 connected to the FB pin (pin 14) of the MAX1937 and produces a negative offset of -100mV.

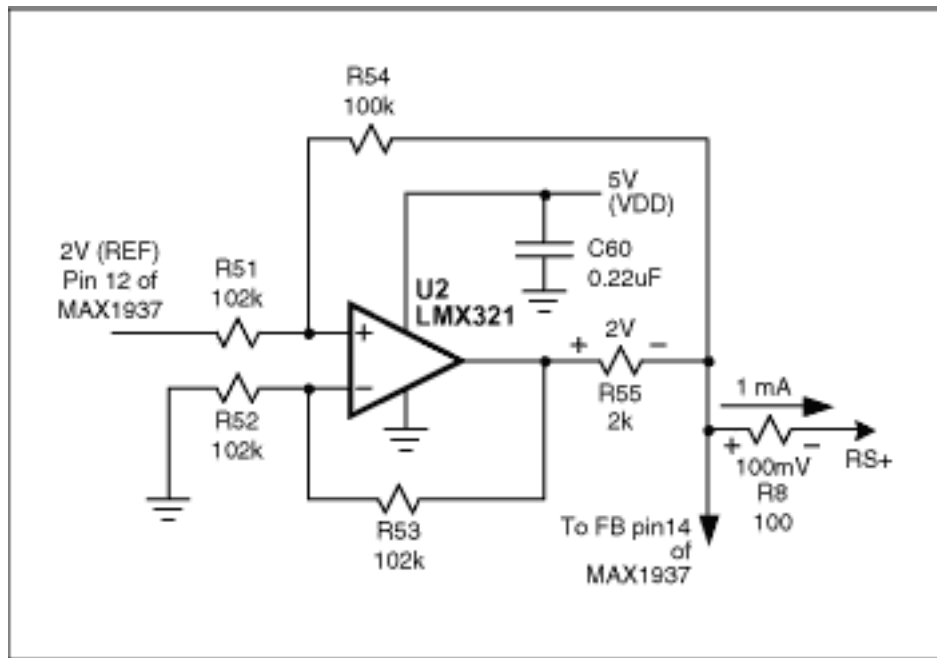

Figure 1 Active Offset circuit

It can be shown mathematically that the output impedance of the above current source is much larger than the load resistance (in this case 100Ω) and therefore its effect on the circuit can be neglected. For a -100mV offset, the accuracy of the above circuit depends on the exact values of the 2 Volt reference ($\pm 13\text{mV}$ for 0 to 85 deg C), the 2k , 1% Resistor R5A and the 100Ω , 1% FB resistor R8. The offset voltage is given by

$$V_{\text{offset}} = \frac{V_{\text{Ref}}}{R5A} \cdot R8$$

Substituting worst-case values in the above equation yields a $\pm 2.6\text{mV}$ worst-case error in the offset voltage. Test data is presented in Table 1 to show selected VID codes and actual output voltage at no load to demonstrate the performance of the active offset circuit. Table 2 shows load line data for the 1.2 volt, 35 watt application.

Table 1 VID codes and actual output voltages with -100mV offset

VID CODE	Vout	Voffset, Target= -100mV
1.3	1.201	0.099
1.275	1.1759	0.0991
1.25	1.1507	0.0993
1.225	1.1256	0.0994
1.2	1.1019	0.0981
1.175	1.0768	0.0982
1.15	1.051	0.099

1.125	1.0265	0.0985
1.1	1.0013	0.0987
1.075	0.9763	0.0987
1.05	0.951	0.099
1.025	0.926	0.099
1	0.9008	0.0992
0.975	0.8759	0.0991
0.95	0.8507	0.0993
0.925	0.8256	0.0994
0.9	0.8004	0.0996
0.875	0.7753	0.0997
0.85	0.7501	0.0999
0.825	0.7249	0.1001
0.8	0.6997	0.1003

Table 2 Load line data for 1.2 Volts VID setting

Iout	Vout	VID CODE	$\Delta V = VID - Vout$
0	1.201	1.3	0.099
2	1.1981	1.3	0.1019
5	1.1924	1.3	0.1076
10	1.1806	1.3	0.1194
15	1.1725	1.3	0.1275
20	1.1641	1.3	0.1359
25	1.1577	1.3	0.1423
27.3	1.152	1.3	0.148

Table 3. Bill of Materials

DESIGNATION	QTY	DESCRIPTION	Vendor
C1, C2, C9, C10	4	10 μ F 25V (1812) TMK432BJ106MM	Taiyo Yuden
C3, C26, C39- C42	6	2.2 μ F 6.3V (0805) JMK107BJ225MA	Taiyo Yuden

C4, C6,C60	3	0.22µF 10V X7R (0603) LMK107BJ224KA	Taiyo Yuden
C24	1	0.47µF 10V X5R (0603) LMK107BJ474KA	Taiyo Yuden
C5, C7, C12, C13	4	4.7nF 50V X7R (0603) GRM39X7F472K50	muRata:
C8, C28	2	1µF 35V (0805) GMK316BJ105ML	Taiyo Yuden
C25	1	47pF 50V C0G (0603) GRM39C0G470J050AD	muRata
C31-C33	3	680µF/2.5V 5m? ESR POSCAP Sanyo: 2R5TPD680M	Sanyo
R2, R5,	2	0 ohms (0603)	
R4, R7	2	200, 5% (0603)	
R8, R9,R28	3	100, 5% (0603)	
R23	1	200k, 1% (0603)	
R24	1	51.1k, 1%, (0603)	
R27	1	10k, 1% (0603)	
R47	1	10, 5% (0603)	
R22	1	90.9k, 1% (0603)	
R25	1	120k, 1% (0603)	
R26	1	100k, 1% (0603)	
R51,R52,R53	3	102k 1%(0603)	
R54	1	100k 1% (0603)	
R55	1	2k 1% (0603)	
R50	1	4.02k, 1% (0603)	
L1, L2	2	0.6uH ETQP1H0R6BFA	Panasonic
D1	1	Dual Schottky Diodes (SOT23) Central: CMPSH-3A Central	
ZD1	1	Zener, 12V Central CMDZ12L	Central
Q1,Q6	2	N-channel Powerpak SO8 MOSFETs,SI7860DP	VISHAY SILICONIX
Q3, Q7	2	N-channel Powerpak SO8 MOSFETs,, SI7356DP	VISHAY SILICONIX
Q15, Q13, Q14	3	2N7002A	Central

PCB	1	4 Phase MAX1937 Evaluation PCB NPCB 07-03 4.5inch x 3 7/8	
U1	1	MAX1937EEI (QSOP)	MAXIM
U2	1	LMX321 Opamp SOT-23-5 / SC70-5,	MAXIM

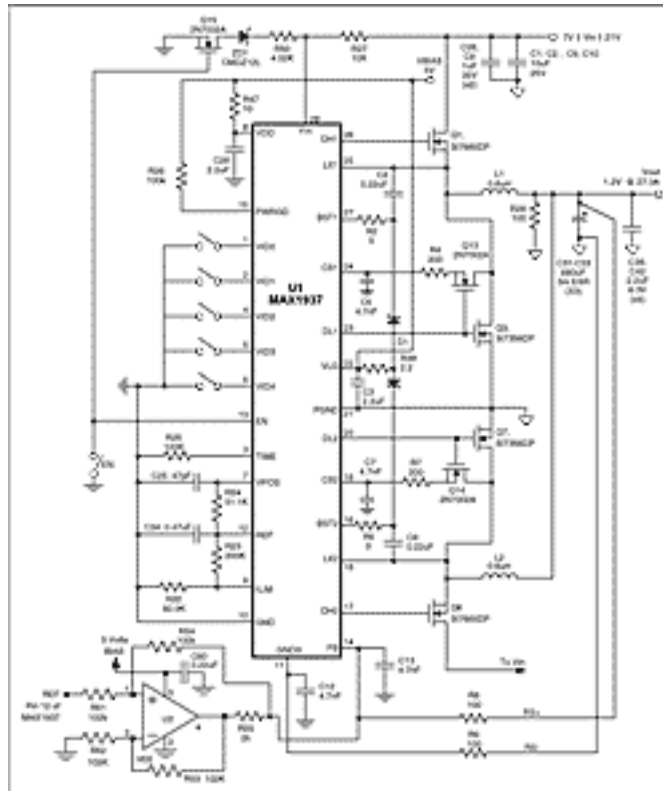

[For Larger Image](#)

More Information

LMX321: [QuickView](#) -- [Full \(PDF\) Data Sheet](#) -- [Free Samples](#)

MAX1937: [QuickView](#) -- [Full \(PDF\) Data Sheet](#) -- [Free Samples](#)

MAX1938: [QuickView](#) -- [Full \(PDF\) Data Sheet](#) -- [Free Samples](#)

MAX1939: [QuickView](#) -- [Full \(PDF\) Data Sheet](#) -- [Free Samples](#)